

### Construction No. 343

**Uplift-Class 90**

**Fire Not Investigated**

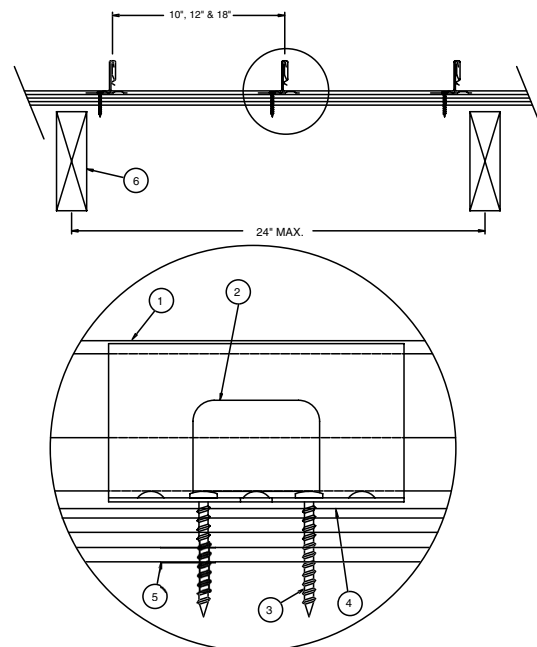

1. **Metal Roof Deck Panels\*** - No. 24 MSG min coated steel, panels, 18 in. wide, 12 in. wide, or 10 in. wide, 1-3/4 in. high at female side rib. Panels continuous over three or more clips with no endlaps. A bead of sealant may be used at panel side joints.  
**Petersen Aluminum Corp** – “Snap-Clad”
2. **Roof Deck Fasteners\* (Panel Clips)** – One piece assembly, 3-1/2 in. wide, 1-7/8 in. high. Min thickness No. 18 MSG. Clips spaced 36 in. OC, max, fastened to plywood deck.  
**Petersen Aluminum Corp** – “Snap-Clad Clip”
3. **Fasteners (Screws)** – Fasteners used to attach panel clips (Item 2) to plywood to be No. 10-12 by 1 in. long pancake head, No. 2 Phillips drive, A-point, coated steel screw. Min two fasteners per clip to be used.
4. **Underlayment** – Underlayment used over plywood deck to be Type 15 or 30 organic felt. Sides overlapped min 2 in., end laps per manufacturer’s instructions. Felt nailed to plywood deck with 1-1/4 in. long steel cap nails, located per manufacturer’s instructions. Nail spacing to be max 12 in. OC at the side lap and max 24 in. OC in interior rows.  
**As an Alternative** – A self-adhering modified bitumen water proofing membrane may be used, installed per manufacturer’s instructions. Note – when alternate is used the plywood joints need not be sealed.
5. **Plywood Decking** – Plywood decking to be graded per PS83 specifications. 19/32 in. thick, exposure 1, APA Rated Sheathing (42/20) square edged. Butt ends not blocked. All butt and side joints to be sealed with a one part urethane caulk sealant applied with a caulking gun and feathered outward from the joint. (Note exception under Item No. 4, Alternate).
6. **Supports** – Spaced max of 24 in. OC. Any of the following types may be used to support the plywood decking:
  - a) Nom 2 by 6 in., No. 2 grade or better S-P-F, Hemlock Fir, Douglas Fir or Southern Yellow Pine or equivalent.
  - b) Wood trusses with a nom 2 by 4 in. upper chord of the same grade as item a.
  - c) No. 22 MSG min cold formed coated steel (min yield to be 33,000 psi).
7. **Plywood Fasteners** – Fasteners used to attach the plywood deck to the supports to be as follows:
  - a) For plywood-to-wood supports No. 8-18 by 1-7/8 in. long bugle-head steel screws with a No. 2 Phillips drive, a “Hi-Low” thread pattern and an “S-Point”.
  - b) As an alternate to Item a, 8d common nails may be used.
  - c) For plywood-to-steel supports for a steel thickness less than No. 20 MSG No. 7-19 by 1-1/4 in. long bugle-head steel screws with a No. 2 Phillips head drive “Hi-Low” threads and an “S-Point”. For a steel thickness greater than No. 20 MSG to No. 16 MSG, No. 6-20 by 1-1/4 in. long bugle-head steel screws with a No. 2 Phillips drive and an S12 (TEKS/3)supR point.

Spacing: Fastener spacing for all fastener types to be 6 in. OC at the plywood edges and 12 in. OC in the interior.  
Refer to General Information, Roof Deck Construction (Building Materials Director) for items not evaluated.

\*Bearing the UL Classification Marking